

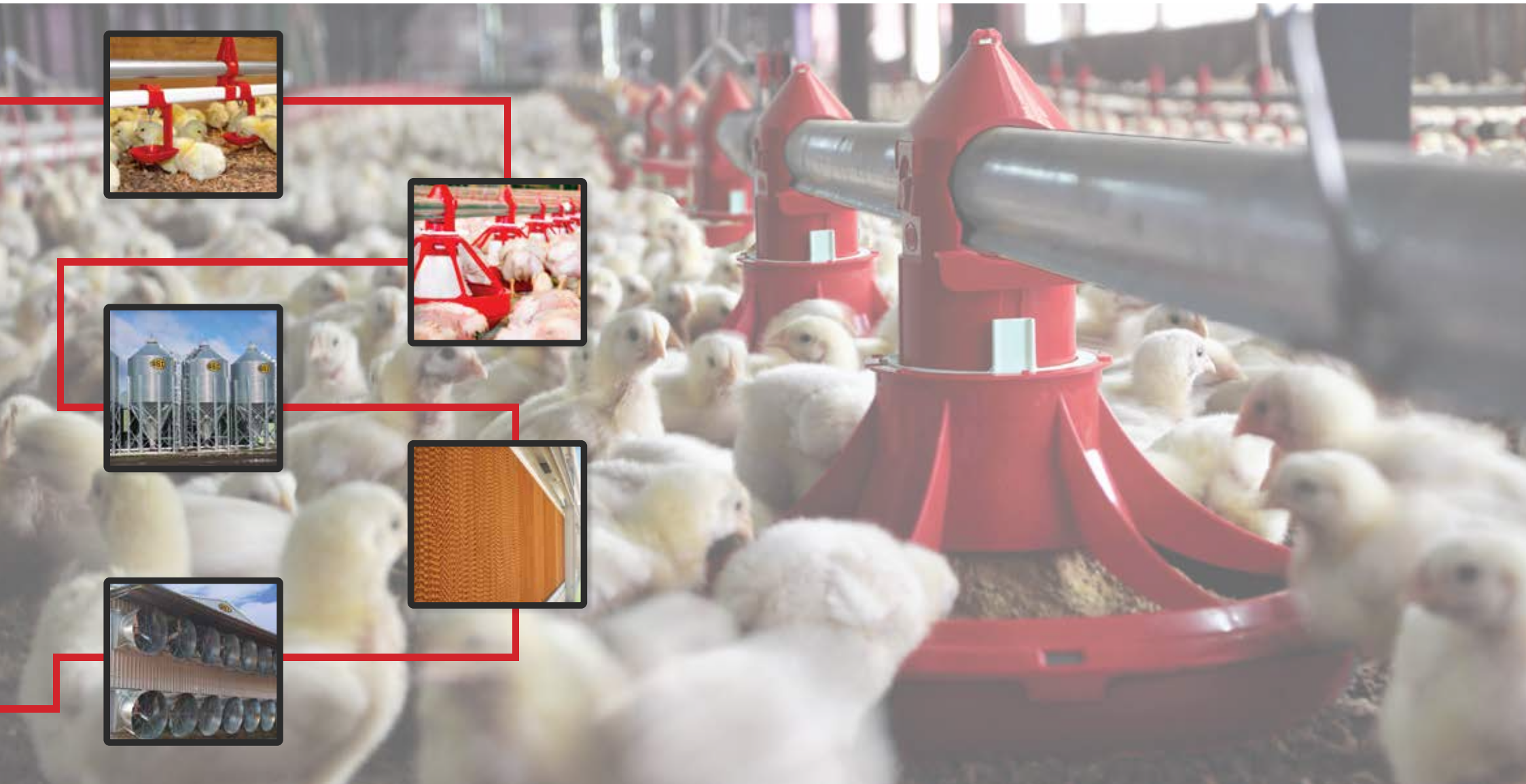

# COMPLETE BROILER SYSTEMS

PROVEN & DEPENDABLE



STORAGE • FEED • WATERING • VENTILATION • HOUSING

# STORAGE SYSTEM



Our Bulk Feed Tanks perfectly illustrate the attention to detail that quality demands. Every stage of the forming process, from corrugation to die-cut shaping to precision finishing, is controlled at our own facilities to assure quality is maintained.

## Bin Roof

Roof panels are precision manufactured using die-form tooling to provide consistent quality. Both 30° and 40° roofs feature reinforcing ribs at each roof seam for added strength and rigidity.

## Unloader

Designed to fit below 16" (406mm) plastic and 22" (559mm) metal boots, Cumberland standard unloader are available for 2.2" (55mm), 3" (75mm), 3.5 (90mm) and 5" (125mm) Flex Flo™ or 4" and 6" rigid auger systems. All Cumberland unloaders have a ultra high impact, polypropylene slide-gate above the auger to meter feed or serve as a complete shut off. Also, a convenient inspection/ clean out plate, located on the side, is easily removed with two wing nuts. Additionally they feature a heavy duty ball bearing for increased service life and reduced maintenance.



Single Unloader shown with optional swing away bottom for 100% clean out

## Lid

- Available for 30° and 40° roof profiles
- Rugged and durable LLDPE plastic construction
- Factory assembled for easy installation
- Simplified clamp-band installation of lid assembly to peak ring
- Reinforce rubber bumper provides additional protection to peak ring
- Internal magnet adds additional force to keep lid closed
- Clamp-band design allows installation in 360° orientation



**Simple Clamp-Band installation with one bolt**



**Magnetic Lock**



**Protective Rubber Bumper**



## Heavy Duty Boots

Cumberland's 16" (40.6cm) parabolic boot (available in straight boot, 30° and straight twin boots) is made from the very latest ultra high impact polypropylene for greater flexibility and durability. Most of our competitors use the older ABS plastic, which is stiff, brittle and prone to fracture, cracking and tear-out, especially where it's attached to steel. ABS is not able to be UV stabilized, unlike our polypropylene resin blend which contains special UV light inhibitors, further enhancing it's durability.



Twin Boot



Straight Drop Boot



30° Drop Boot

## Sure-Flo

An affordable and simple way to prevent bridging and promote even feed flow in feed bins!

- Reduces feed bridging
- First in, first out feed flow
- Reduces feed separation
- Easy to install

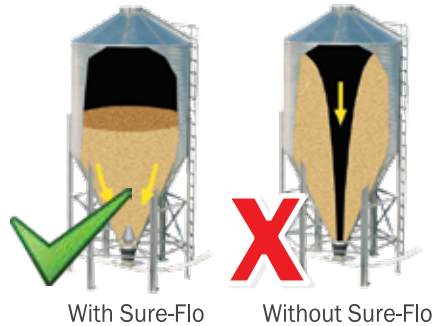

With Sure-Flo

Without Sure-Flo



The Sure-Flo support bracket easily bolts to the hopper collar of new or existing feed bins and is quick and simple to install.



Sure-Flo directs feed down the hopper the bin rather than down the center creating a first in, first out feed flow. The gentle movement of the heavy walled molded cone enhances flow as feed passes over it.



## Bin Load Cell

- Each load cell has 10000lbs capacity
- Lightning protection at each load cell
- Accuracy over the entire linear range
- Accuracy and durability to withstand lightning, wind and temperature fluctuations



Target Load Cell Support



Target Load Cell

## Reliable Construction



Precision Manufactured Roof Panels, provide consistent quality and feature reinforced ribs at each seam for added strength and rigidity on both the 30° and 40° bin roof options.



High Strength Ladders with roll-formed sides are available in 2' and 9' sections for quick assembly. Ladder rungs are engineered to eliminate rung spin and are dimpled for a better grip.



Fully galvanized, Roll Formed 6-Bend Legs, Cross Ties and Two Piece Leg Anchor Sections provide greater strength, stability, support and load transfer. Tank hoppers are available in 45°, 60° and 67° slopes. Die-formed with a down turned sealed edge provides a weather-tight fit and smooth flow of material.



Ladder cages are available for all Bulk Feed Tank sizes. Cages are completely galvanized for maximum life and bolt directly to the prepunched side wall ladders. The cage bottom Bell Section allows ample maneuvering space while ascending or descending.

## Bulk Feed Tanks Models:

Part Number					Maximum Capacity			Overall Height	
Model	Diameter Feet	Diameter Meters	Ring	Angle of Hopper	Cubic Feet	Cubic Meters	Metric Tons	Feet	Meters
BFT	6	1.83	1	60°	147.60	44.98	2.67	11.3"	3.43
BFT	6	1.83	2	60°	222.21	67.73	4.03	13'11"	4.25
BFT	6	1.83	3	60°	296.82	90.47	5.38	16'7"	5.06
BFT	6	1.83	4	60°	371.43	113.21	6.74	19'3"	5.87
BFT	7	2.13	1	67°	244.96	74.67	4.44	14'3"	4.35
BFT	7	2.13	2	67°	346.51	105.62	6.29	16'11"	5.16
BFT	7	2.13	3	67°	448.06	136.57	8.13	19'7"	5.97
BFT	7	2.13	4	67°	549.61	167.52	9.97	22'3"	6.78
BFT	7	2.13	5	67°	651.16	198.47	11.82	24'11"	7.60
BFT	7	2.13	6	67°	752.71	229.43	13.66	27'7"	8.41
BFT	9	2.74	1	60°	413.81	126.13	7.51	15'1"	4.59
BFT	9	2.74	2	60°	581.68	177.30	10.56	17'9"	5.41
BFT	9	2.74	3	60°	749.55	288.46	13.60	20'5"	6.24
BFT	9	2.74	4	60°	917.42	279.63	16.65	23'1"	6.74
BFT	9	2.74	5	60°	1085.28	330.79	19.70	25'9"	7.85
BFT	9	2.74	6	60°	1253.15	381.96	22.75	28'5"	8.66
BFT	12	3.66	2	60°	1177.87	359.01	21.38	21'11"	6.67
BFT	12	3.66	3	60°	1476.30	449.98	26.80	24'7"	7.49
BFT	12	3.66	4	60°	1774.73	540.94	32.22	27'3"	8.30
BFT	12	3.66	5	60°	2073.17	631.90	37.64	29'11"	9.11
BFT	12	3.65	6	60°	2371.60	722.86	43.05	32'7"	9.93
BFT	15	4.57	2	60°	2064.39	629.23	37.48	25'10"	7.87
BFT	15	4.57	3	60°	2530.69	771.35	45.94	28'6"	8.68
BFT	15	4.57	4	60°	2996.99	913.48	54.41	31'2"	9.50
BFT	15	4.57	5	60°	3463.29	1055.61	62.84	33'10"	10.31

## Flex-Flo™ System

Cumberland offers five Flex-Flo™ models with capacities ranging from 15lbs. to 220lbs./minute (6.8kg to 99.8kg/min) whether it's ground feed, crumble feed, mash, high moisture corn, shelled corn or pellets, Cumberland has the equipment to handle it. For corn with up to 27% moisture and other hard to flow materials, Cumberland also offers a Flex-Flo™ High Roughage system which incorporates a special combination of a 3" (75mm) auger in a 3-1/2 (90mm) tube to reduce plugging.



### Special Blend

Polyvinyl chloride (PVC) tubing is extruded and formed in our own facility, to exacting standards and under our own quality control. Blended PVC allows us to formulate the optimum compound for UV stabilization, strength and wear resistance.



### Quality Auger

Cumberland augers are coiled in-house from high tensile steel. The wire used is flattened prior to hardening, providing for a more consistent, high quality product.

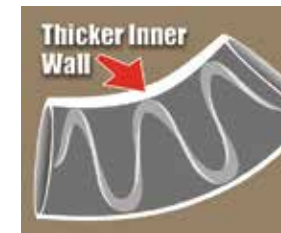

### Around the Bend

For moving feed up in the air and around corners. Flex-Flo™ tubing is available in specially formed elbows with increased wall thickness on the inside of the elbow for strength and wear resistance.



Flex-Flo™ Models	Model 220	Model 300	Model HR	Model 350	Model 500
Tube Outside Diameter	2.25"	3"	3.5"	3.5"	5"
Tube Outside Diameter (mm)	55	75	90	75	125
Tube Corner Radius	5'/10'	5'	5'	5'	5'
Tube Corner Radius (m)	3.05	1.83	1.53	1.83	1.83
Max. Single System Length with Three Elbows	250'	200'	150'	150'	*150'
Max. Single System Length (m) with Three Elbows	76.2	69.96	45.72	45.72	*45.72
Recommended Motor Sizes at Max. Length (Horsepower)	0.5	1	1	1	1.5
Capacity (Lbs./Minute at 40 Lbs. per Cu. Ft)	15	50	50	100	220
Capacity (Lbs./Minute at 640 kg. per Cu. Ft)	480	1360	1360	2722	480
Extension Length (Motor End of First System) w/o Elbows	300'	235'	185'	185'	*185'
Extension Length (Motor End of First System) (m) w/o Elbows	92	72	56	56	*56

### Extension Hopper

For applications requiring distance greater than the standard length of any given system, extension hoppers are available that can expand the delivery range to practically any distance and can provide access at 90° from the main line.



Power Direct-Drive Unit



Direct-Drive Unit & Straight Transition Boot



Belt-Drive Unit

### Flow Hammer

Feed bridging has become a common event in the poultry industry as feed rations change due to fluctuating input costs and the use of alternative feed stuffs to lower cost and gain feed efficiency. The “Flow Hammer” is a reliable and affordable solution that easily adapts to most existing feed bins. This product aids in the prevention of out of feed events in all phases of poultry production.

- Helps minimize feed bridging events to keep feed flowing consistently to animals
- Low maintenance and simple installation (no field modifications to the tank required)
- Control unit has both timer and sensor controlled modes:
  - The timed mode uses an “on” time and a “cycle” time to control the flow Hammer when the feed system is running.
  - The sensor mode uses a sensing device to detect a feed flow issues and activates the Flow Hammer. Once the event has ended, the Flow Hammer shuts off
- Control unit can be remotely mounted or tank mounted with optional leg bracket



Over 500lbs/sec



Comparing to high frequency vibration devices, which are effective in promoting feed flow, but results in loosened hardware and metal fatigue potentially resulting in structural failure, our FLOW HAMMER's low frequency/ high impact design promoted feed flow without damaging your feed bin or voiding its warranty.



# PAN FEEDING

## Hi-Lo Plus

**External adjustment ring**  
Easy feed level adjustment. Keep feed hygiene.

**Detachable drop tube**  
Sliding top cap for fast installation, secure connection with tube.

**Smooth edge rim design**  
Reduce waste and bird safe.



Hi-Lo Plus is the farm-tested result-proven feeding pan, which carries and maintains all the successful features from years of practice and experience. Putting the birds' comfort and farmers' convenience first, the new Hi-Lo Plus is thoughtfully engineered for both farmers' and birds' satisfaction. The high-low adjustable feature and swingable design provide birds an ergonomic feeding position throughout the entire life cycle. The unique structure makes assembling the pan easy for every farmer and satisfies GSI's high quality and performance standard.

## Hi-Lo Classic Pan & Hi-Lo VIII Pan



Two-Stage pan performance inside one complete feeder is the idea behind Cumberland's revolutionary Hi-Lo Pan Feeding System. The Hi-Lo pan feeder represents a unique concept in the poultry industry, using one feeder to take from day-old through adult. The first ten days of a broiler chick is critical. The Hi-Lo pan feeder can start on the house floor, presenting a lip height of 2.1" (5.33cm), the average height of traditional "chick lids". As the bird grows, the feeding line needs to be raised. The Hi-Lo is able to expand into a 3.5" (8.89cm) deep pan. The higher wall and feed saver lip prevent waste from raking and spill out.



The **telescoping drop tube** automatically compensates for uneven floor conditions. The drop tube is available in either the standard one piece or optional two pieces design.



### 360° Action

The combination of drop tube and grill allows movement in 360°, reducing bruising and injury to the birds.



### Feed Depth Control

Feed depth control measures directly from the bottom of the pan, assuring all birds a consistent and even supply for fresh feed.



### Two Stages

Collapsed (2.1") and Expanded (3.5")

## EZ Flood Pan



The EZ Flood Pan is suited for day-old chicks until full grown. The design concept of EZ Pan is to allow maximum flooding feed when the pan is set at the lowest position

### NOTE:

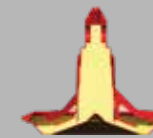

winch up position gives minimum feed level

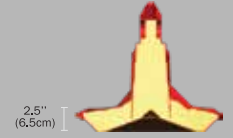

winch down floor position gives maximum flood feed

## M Series (7 & 14 spoke design)

The M Series Pan is suited for day-old chicks until adult. It is made from high quality materials with high corrosion resistance and UV resistance. The wide spokes will reduce bruising and injury to the birds. The higher wall and feed saver lip helps prevent wastage.



## MY Pan

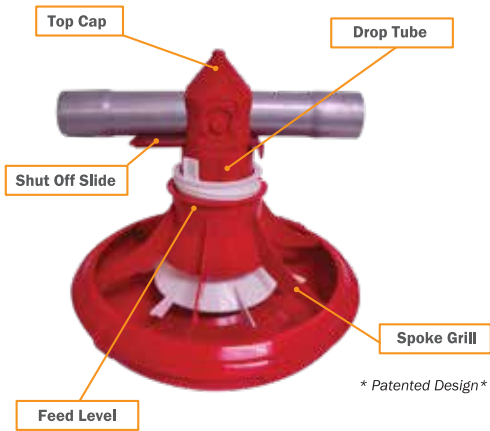

\* Patented Design\*

My pan is a comprehensive feeding pan that is easy to install and operate, designed for day-old chicks till harvest

- Detachable Drop Tube
- 6 Stages Rotating Feed Level
- Flood Window
- Anti Scratch Fin
- Optional Shut off

### Non flooding minimum feeding position

When the feeder is winched up above the floor, the flood feed window will shut off and minimize the feed to flow through the saving ring.



### Flood feed position

When the feeder is seated on the floor, the feeding window will give maximum flooding feed. The shallow pan is designed with a feed-saving lip that prevents waste and allows day-old chicks to access the feed easily.



## Tubing & Auger

The rib on Cumberland's lock formed tubing gives added strength to the tube, as well as providing a solid way to hold the pans in place. The auger is manufactured from pre-flattened wire to reduce material stress and provide for a more consistent, high quality product.

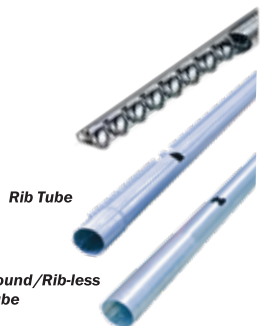

## Poultry Boots

Heavy fabricated, galvanized, single and double outlet boots are available for end or center housing feeding applications



Feed Level Switch

## Hopper Feed Level Switch

Traditional micro switch hopper level controls are available to regulate feed delivery.

## i-Plus 3 Control Pan



After first 8 days brooding, elevate feeder line 1 cm every 3 days.

Cumberland offers a variety of control pans for your feeder line. Choose from I-PLUS 3, proximity switch, micro, switch to Cumberland's exclusive control pan. All control pan models are durably constructed and assure consistent feed regulation.

The i-plus 3 control pan feeding system utilizes **Infrared technology** to detect the level of feed in the control pan for proper and reliable operation. Infrared technology does not require any moving mechanical mechanism or sensitivity adjustments.



As the i-plus3 Control Pan fills, the infrared beams detect the feed levels.



When the feed level breaks all three of the infrared sensors, the auger will stop automatically.



When the feed drops below the infrared sensors, the auger will re-start automatically after **60 seconds** delay.

# WATERING SYSTEMS

Cumberland's experience and engineering continue to bring you a complete watering system loaded with innovation and features that promote large healthy birds and dry floors.



\* Round pipe system for demonstration

- |                         |                                   |                        |
|-------------------------|-----------------------------------|------------------------|
| <b>1. Sight gauge</b>   | <b>5. Nipple</b>                  | <b>9. Flush</b>        |
| <b>2. End kit</b>       | <b>6. Conduit support pipe</b>    | <b>10. Water inlet</b> |
| <b>3. Shocker cable</b> | <b>7. Regulator mount bracket</b> |                        |
| <b>4' Drinker cup</b>   | <b>8. Regulator</b>               |                        |

Cumberland Watering Systems deliver superior overall performance, meets the highest global standard.

## Watering System

This system features an important innovation: using ball valve sitting on toggle pin. It has a 360 side-to-side toggle action screw in nipple, which makes drinking four times easier than ever before. The upper metering ball precisely control the flow of water through the valve and the high quality snap on drip cup which keeps the litter dry.

## Nipple & Drip Cup

- Cumberland uses hardened high grade stainless steel balls for a tighter seal and accurate flow control
- Inner components are contained and will not disassemble during shipping
- Screw in nipple uses all stainless steel components manufactured in USA
- No special wrench required for assembly



Round Pipe System

## Twin Lock Nipple Valves

- 4 different styles available to meet all watering needs
- Only 3 moving parts
- Extra long life
- 360° toggle
- Four times easier action
- Quick and easy assembly (no wrench required)
- High precision stainless steel ball and seat
- Lower pin drinking cavity attracts chicks
- Standard Twin Lock connection interchanges with other brands
- The double locking feature compresses and seals the o-ring uniformly around the drinker

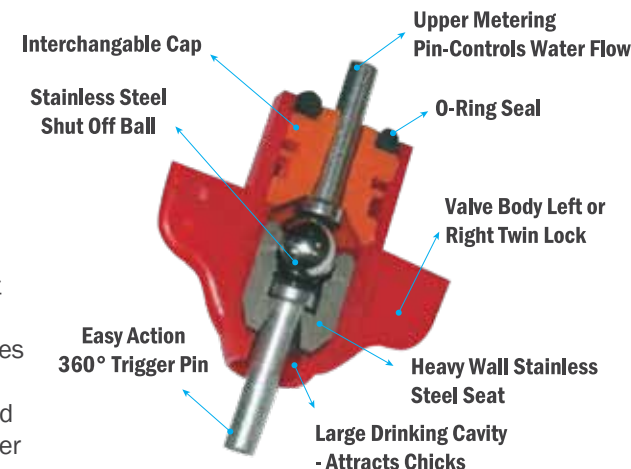

## Twin Lock Design | Stainless Nipple Valves

Grey	CW-9580T
Orange	CW-9440T
White	CW-9197T
Purple	CW-10233T

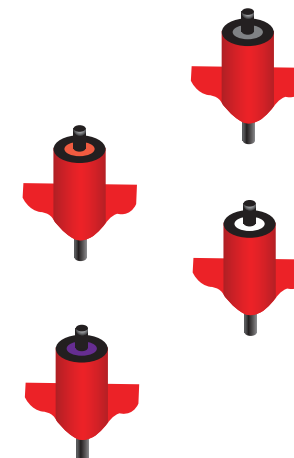
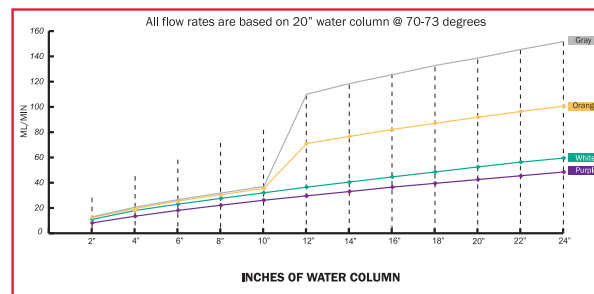

## Self Sealing Cap



Self sealing cap at clear sight tube to prevent water spillage.



## Stainless Steel CW-10015



Pushed In		Side Action	
Water Level (cm)	Minute (ml)	Water Level (cm)	Minute (ml)
10	57	10	26
20	86	20	56
30	119	30	72
40	138	40	98

## Plastic Nipple CW-P10013



Pushed In		Side Action	
Water Level (cm)	Minute (ml)	Water Level (cm)	Minute (ml)
10	50	10	45
20	72	20	70
30	101	30	92



### Features:

- Easily triggered with 360° side-action pin
- Stainless steel nipple with flow rate 56-86 ml/min
- Removable top pin
- Plastic nipple with flow rate of 70-72 ml/min



### Air Vent

- Bleeds air from high spots
- Offers mid-line sight gauge reading
- Can be installed anywhere



### End Kit-Auto Flush

- Extra strong design
- All flexible sight gauge allows easy pressure reading
- Require no valve at end kit to flush



### Regulator for Both Round and Square Pipe Systems

- Delivers high volume of water at an adjustable pressure
- Heavy-duty
- Square pipe adaptor available as an accessory for square pipe systems.

## Water Regulator

Flushing of the Cumberland Watering System requires no extra plumbing and valves. The Cumberland Regulator can be easily removed from the watering line without interfering with the suspension of the watering line. The heavy-duty housing of the Cumberland Water Regulator design allows higher incoming water pressure and helps to prevent any leakage where housing is bolted together. Square pipe adaptor kit is available for Square Pipe System.



#### Convenient Flush

GSI's unique flush lever is designed for greater versatility and ease of use, no by-pass necessary



#### Removable End Cap

This regulator can be easily removed from the watering line without interfering with the suspension of the watering line.

With the unique in-line design, it can be used as a mid-line regulator by simply removing the end cap.

# VENTILATION FANS



## Megaflow Galvanized Fans

### Lower Cost, Higher Profits

Cumberland ventilation systems are the perfect solution for more efficient, high performance, climate control in poultry production facilities. Our equipment has been field refined and industry proven to be extremely effective in reducing bird stress caused by overheated or poorly ventilated houses. Even if your building is well ventilated, inefficient equipment can blow healthy bird profits right out the window. If you're looking for a better return on your investment, go for Cumberland, your ventilation expert.



## Slantwall Fans

Cumberland offers 36" and 50" galvanized steel belt drive slantwall fans to maintain optimal environmental conditions efficiently and effectively. All galvanized fans are constructed of heavy gauge, G-90 grade galvanized steel and use high efficiency motor for continuous duty cycles. Galvanized fans propellers are aerodynamically balanced for maximum air flow.

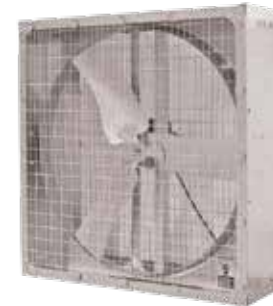

## Box Fans

Cumberland offers 36" and 50" galvanized steel belt box fans to maintain optimal environmental conditions efficiently and effectively. All galvanized fans are constructed of heavy gauge, G-90 grade galvanized steel and use high efficiency motor for continuous duty cycles. Galvanized fans propellers are aerodynamically balanced for maximum air flow.



## 51" & 69" Euro Fan

Cumberland 51" & 69" Euro fan are designed for multiple applications and provide excellent air circulation.

- Stainless steel fan blade for excellent corrosion resistance
- V-belt plastic safety protection cover
- Plastic venturi for better corrosion resistant and easy to clean for optimal hygiene
- Robust and strong internal X-support structure
- Materials resistant against aggressive climates
- Galvanized shutter with Centrifugal Shutter opening system
- Fully concealed and maintenance free bearing

*\* 6 blade cone fan only available in 52" model.*



**3 Blade Cone Fan    6 Blade Cone Fan**

## Cone Fans

Optional discharge cones can boost fan output by as much as 10-15%, greatly increasing efficiency. Made from all galvanized steel, cones are available in easy to ship and assemble four-piece segments for 36", 50" & 52" models.



## Galvanized Fan Performance Values

Model	Hz	Dia.	Drive	Type	HP	.05 Static Pressure		.10 Static Pressure		Remarks
						CFM	CFM/Watt	CFM	CFM/Watt	
X36GB	50	36	Belt	Box	0.5	7867	34.4	7260	30.5	Wire Grill
X36GSHB	50	36	Belt	Box/Shutter	0.5	6476	26.9	5812	23	PVC Shutter
X36GCB	50	36	Belt	SW CONE	0.5	7444	33.2	6667	27.8	PVC Shutter
X50GSHB	50	50	Belt	Box/ Shutter	1.5	18820	14.8	17396	13.4	PVC Shutter
X50GCB	50	50	Belt	SW CONE	1.5	21420	19	19680	16.9	PVC Shutter
X52GCB	50	52	Belt	SW CONE	1.5	21522	19.6	19558	17	PVC Shutter
X52GCB	50	52	Belt	SW CONE	1.5	23688	23.1	22181	20.8	Aluminium Shutter

\* All test with PVC shutter. \* All 50Hz fan result are test by GSI China fan test chamber. \* All model are available in 60Hz

## Euro Fan Performance Values

Model	Hz	Dia.	Drive	Type	HP	.04 Static Pressure		.12 Static Pressure	
						CFM	CFM/Watt	CFM	CFM/Watt
X51G6B-SS	50	51"	Belt	Box	1.5	22,765	13.39	20,949	12.32
X69G6B-SS	50	69"	Belt	Box	2.0	40,909	19.48	36,826	17.54

## Megaflow External Damper Fans

### Lower Cost, Higher Profits

The Mega Flow External Damper Fan (Mega Flow ED) follows the footsteps of its top of the line Mega Flow predecessors, boasting the industry's highest performance in a galvanized fan. The External Damper line has been completely re-engineered upgraded from the ground up to insure optimum levels of both quality as well as performance. Increasing air flow during operation and providing an unsurpassed complete seal when closed.

Our innovative AddAire butterfly style shutter system comes in standard on all Mega flow ED models. Due to the fact that minimal dust and debris is collected by the AddAire Shutter, the efficiency and performance of the unit will remain at their optimum levels for the life of the fan.

- Doors remain fully opened under extreme static pressure due to the patented AddAire wings
- Magnetic shutter panel right eliminates movement of shutter when not in use and creates a complete seal
- Super efficiency totally enclosed air over energy efficient motors
- Four piece galvanized cone for ease of installation
- Available with good label cog v-belt with automatic belt tensioner or powertwist link belt
- Pillow block bearings



## Light Trap

### Features:

- High light reduction
- PVC extrusion profile protects against sunlight and high temperatures
- Resistance to corrosion and deterioration
- Easy installation and maintenance

## Fan Shutters

Available in a variety of size and materials, we have a shutter to fit your particular requirements it low light, low maintenance or low cost. The true airfoil design of our shutter blades make them streamline the exhaust air flow with very little performance loss. Simple to install and built to last a lifetime. Cumberland shutters can provide an easy and affordable means of controlling incoming light and building climate.



Aluminum PVC (White)

Cumberland PVC shutters come in white or black colour, which requires very low maintenance and easy to clean. The black shutters are used to reduce lighting applications. Aluminium shutters are also available for great durability in any environment. All shutters are rustproofing and practically maintenance free.

## Butterfly galvanized fan performance values

Model	Dia.	Drive	Phase	0.0 Static Pressure		0.05 Static Pressure		0.10 Static Pressure		0.15 Static Pressure		0.20 Static Pressure		BESS Lab Test #
				CFM	CFM/Watt	CFM	CFM/Watt	CFM	CFM/Watt	CFM	CFM/Watt	CFM	CFM/Watt	
77-0125-1B	52"	Belt	3	30,700	24.9	29,000	21.9	27,300	19.4	25,400	16.9	23,000	14.5	05332-C
77-0128-1B	52"	Belt	3	29,300	25.0	27,500	21.9	25,700	19.3	23,500	16.8	21,100	14.3	05334-C
77-0144-1B	54"	Belt	1	31,800	23.7	30,300	21.2	28,700	19.0	27,000	17.0	23,900	14.0	14157
77-0153-1B	54"	Belt	3	32,000	23.7	30,600	21.4	29,000	19.2	27,200	17.1	25,300	15.2	14165

\*77-0125-1B,77-0144-1B,77-0153-1B were tested in 60Hz

\*77-0128-1B was tested with 50 Hz

## Mega Flow External Damper Fans

AddAire is a feature that allows the butterfly style doors to be fully opened and remain fully opened under extreme levels of static pressure.



# ATTIC VENTS & VENT DOOR SYSTEMS

## Easy Intall Attic Vents

Cumberland's Attic Vent ACI Series is precision engineered to extract solar heat from the attic space so it can be used as a valuable heat source. This unique and innovative design is cost effective, durable and easy to insyall



Incorporating all of the same benefits of the ACI-2500 and ACI-4000 Series, Cumberland's PACI-2500 Series vents are pressure actuated and operated by constant force of static pressure controlled springs

The Attic Vent System is designed to be retrofit friendly in most drop ceiling poultry houses.



### Benefits of Cumberland Attic Vent:

- Drier litter
- Lower ammonia concentration levels
- Better environment for the bird

PVC Plastic Frame



Galvanized Frame



### Specifications:

Part Number	Description	CFM at Full Open Airflow @ 0.10SP	CFM at Horizontal Airflow @ 0.10SP	Framed Opening
ACI-2500P2	All Plastic Actuated Ceiling Inlet	2500	1700	19" W x 27"L
ACI-2500GP2	Actuated Ceiling Inlet (Galvanized Frame)	2500	1700	21.5"W x 27"L
ACI-4000P2	All Plastic Actuated Ceiling Inlet	4000	2500	19" W x 46.5"L
ACI-4000GP2	Actuated Ceiling Inlet (Galvanized Frame)	4000	2500	21.5" W x 46.5"L
PACI-2500GP2	Plastic 2500 Pressure Actuated Attic Vent (Galvanized Frame)	2100	1300	21.5" W x 27"L
PACI-2500P2	All Plastic 2500 Pressure Actuated Attic Vent	2100	1300	19" W x 27"L

## Have You Ever Considered Using Attic Heat as Green Solar Energy for Brooding?

### Operation

Vents are operated with a linear actuator or curtain machine and are controlled by your ventilation controller.

### House Conditions

Significant benefits to Cumberland's Attic vents are drier litter and lower ammonia concentration levels, thus providing a better in house environment for the birds.

### Retrofit Friendly

The Attic Vent System is designed to be retrofit friendly in most drop ceiling poultry houses.

### Unique Door Design

Exceptional air mixing due to the curved door profile which provides proper air velocity directing warm air from the attic into the house.

### Fuel Savings

Mixing warm air from the attic with house air during minimum ventilation reduces fuel consumption as compared to using cold air through sidewall inlets. Fuel savings can vary depending on management, house construction and climate

## Sidewall Vent Doors

Cumberland's vent doors are used in poultry applications where transitional ventilation is required. Vent doors comes with galvanized or plastic which are easy to install. These doors are maintenance free and will provide optimum circulation for many years.



Plastic curved door directs fresh air into the house along the ceiling toward the peak for gentle air mixing without downdrafts on the birds and is ideal for wider poultry houses.

### Specifications:

Part Number	Description	CFM at 0.10SP	Rough Opening
6612-4408RCN	Plastic Vent Door	1816	8.75" x 44.50"
6612-4413RCN	Plastic Vent Door	2953	13.50" x 44.50"
07501387	GI Vent Door	-	12.85" x 63"
07502334	GI Vent Door	-	11.8" x 48"



# EDGE CONTROLLER

“The Next Generation Controls for IoT Smart farming”



EDGE® is a single platform that is versatile and intuitive allowing it to handle all control applications. The unique design makes EDGE the only controller on the market that can be configured to match your operation’s specific requirements. It is also flexible enough to be adapted to new construction or existing system upgrades. Throughout your animals’ growth stages, you and EDGE are in control, managing and monitoring ventilation, cooling, heating, lighting, feeding and watering systems.



## EDGE Key Features:



Three levels of protection, including triple redundancy and built-in backup mode, which we make it the safest, most reliable controller in the industry.

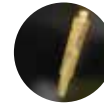

LED temperature probes, patent-pending technology that simplifies installation and eliminates the hassle of having to individually identify the location of each probe.



Online remote access via GSEdge.com, enabling farmers to manage and administer multiple sites and houses from the comfort of their home, house or other off-site location.

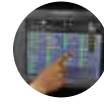

Navigation is easy with the large, 15” color touchscreen. Everything is right in front of you for quick, easy navigation. The buttons are large enough to be touched even when wearing gloves. Color-coded notifications give you real-time status of your entire operation. Site-wide conditions can also be monitored from the touchscreen.



Monitor feed storage, track feed levels and automatically e-mail the feed mill when bins are getting low with the EDGE Bin Scale.



Optional remote display boxes give producers the ability to view and modify control settings from any location, regardless of main controller’s location.



Fully dimmable lighting, which works with any lighting technology and controls lighting from low-end output to 100%.



The ability to train employees on one system that will work the same anywhere in the world.



Control multiple barns from a single controller using one interface. Historically, each room would require a separate controller. EDGE reduces management complexity and offers you considerable cost savings by eliminating the need to have a separate controller for each individual house.

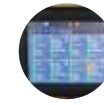

Should anything go wrong, the built-in self-diagnostics make troubleshooting easy. Before you go flipping through a manual or calling tech support, self-diagnostics can identify a number of issues. The system can tell you when a sensor is disconnected or incorrectly wired, if a piece of equipment is drawing too much or too little current, or if internet connectivity is down. It will pinpoint exactly where the problem is and what you need to do to fix it.



The built-in Configuration Wizard is designed to guide you through the initial set-up by prompting you with questions about each of the specific applications that have been installed. Simply input the fans, inlets, temperature probes, lights and other equipment you have, where they are located and the production type (broiler, breeder, layer, pullet, turkey). Based on this information, EDGE will automatically configure run settings to operate at the optimal conditions.

# CONTROLLING SYSTEM

## TC4-4SD - 4 Stage Controller



- Four on/off climate controller for fan or heater
- Up to two heater outputs
- Minimum ventilation on/off timer
- Up to four fan outputs
- Back up for TC5
- Automatic temperature reduction

## TC4-8SD 8 on/off Stage Controller



- 3 digit display with pilot light indication status
- Up to four independent temperature probe inputs
- Parameter protection (Lock Mode)
- Can be powered with 115/230V AC (50&60Hz) or 12V DC
- Minimum ventilation cycle
- Temperature curve
- Computer compatible
- Overvoltage protection

## Alert Alarm III



- Detects high limit and low limit set point temperatures. If any of these do not meet the requirements, it will trigger the alarm signal
- It can be equipped with 2 temperature sensors and 2 auxiliary inputs from other controllers
- It has built in backup battery that can last up to 2 hours
- Has its own backup siren
- Power supply: 120V AC or 240V AC 50/60 Hz
- Temperature range: 0°C – 55°C
- Outputs: 1 @ 12V DC and 1 AMP inputs
- 2 temperature probes or TC4-4SD board to work as slave

## TC5-8SDA - 8 Stage Controller



- Eight on/off climate controls for fans or heater
- Up to eight fan outputs
- Up to two heat outputs
- Up to one cooling output
- Minimum ventilation on/off timer
- Automatic temperature reduction
- Optional: humidity sensor
- Alarm equipped

## Bird Scale



Help you reduce mortality rate and reach your desired target. The attractive platform encourages birds to hop onto the scale. The more weight hit each day, the more accurate the house average weight will be. This bird hanging scale kit includes the bird platform and the LCT-1 load cell.

### Features

- Easy to use
- Push-button access to information:
  - Average and number of weight
  - Standard deviation, uniformity and daily gain
- Weigh your birds throughout the day
- Featherweight can have up to 4 platforms – 2 in each house. Each platform has an independent reading. Any platform can be assigned to house 1 or house 2
- Maximum weight of 50kg
- Trade quality Load Cell
- Load cell is located above the platform away from the litter
- Litter and manure build-up do not influence weighing accuracy
- No electrical wires under the platform





## Electronic Controller Expert LA



- Ventilation based on static pressure and temperature
- 2 timed curtain output
- Up to 16 relay output
- Feeder, heater runtime and water monitoring are saved in memory for up to 75 days
- Upload and download chip to easily transfer all the settings (up to 15 different programs)
- 2 air inlets, 2 natural curtain outputs and 2 tunnel outputs
- Energy saver features
- Seamless ventilation step between stages

- PC programmable (optional)
- Minimum ventilation curve strategy and status LED
- Stage 1 fan ramping feature
- Up to 8 inside and 2 outside temperature probe
- 4 heating stage with Hi/Low for up to 75 days
- Light program
- Two 0-10 volts outputs
- 1 cooling stage with programmable cycle timer and relative humidity (RH) override feature when the maximum RH set point is reached
- Clean mode can be activated for empty rooms
- Alarm monitoring
- 3 controller programs that can be changed manually by age and by outside temperature

- Copy and paste feature within control
- Memory chip
- Multiple password protected user levels or optional no passwords
- Sensor calibration
- Misting, age and mortality
- Longer histories (timed and dated)
  - Room temperature 60 days
  - Inside probe temperature 10 days
  - Outside temperature 75 days
  - Humidity 75 days
  - Heater run time 75 days
  - Feeder run time 75 days
  - Daily water consumption 75 days

## Environmental Electrical Control Panel



### Wall mount control system

This control systems range from:

- Ventilation control system
- Feeding control system
- Lighting control system
- Winching control system



Complete Unit

### Optional large cabinet for whole house control panel

- Evolution secondary sensing systems
- Lighting distribution control systems
- Feeding distribution control systems
- Ventilation control systems
- Base/plinth, complete 100mm high
- TC5 - 8SDA
- Lifting eyebolts
- Divide mounting plate

## Relay panel manual motor starters for control systems



This relay panel manual motor starters provide protection against:

- Overload
- Short circuit
- Phase failure
- Under voltage

Fuseless protection saves cost, space and provides for quick reaction under short circuit conditions, switching the motor off within 3ms. It is therefore an easy to handle, cost effective protection solution.

# AGRI ALERT ALARM SYSTEM



## Agri-Alert™ 800EZE

- Graphical LCD screen
  - View information quickly & clearly
  - Intuitive screen design
  - Easy navigation through menus
- Monitor up to 8 zones
- Acknowledge alarms by phone
- Call in from off site for zone temperature and system status report



## Agri-Alert™ 128 Touch

- 7-inch color touch screen allows all zones to be seen at once
- Internet connectivity provides remote access, eliminating your need to go to the barn
- Email and SMS notifications
- Modular architecture allows you to design a system that's the right size for your operation
- 128 zones let you monitor a large site with a single system
- Phone dialer provides dependable delivery of alarm notification
- Built-in security makes sure only authorized users can adjust the system
- Fully compatible AA9600 replacement

## Wireless Option

Go wireless with RS-485 modules. This module can be programmed as a receiver or transmitter with a range of up to 6,500 feet\*. This wireless module is typically used in combination with a main controller (AA128 Touch, or AA9600). A secondary wireless RS-485 transmitter can be utilized to relay information from remote RS-485 modules to the wireless RS-485 (Base). This allows a variety of configuration options to accommodate your particular needs.

## Typical Site For An AA128 System

Wireless system allows establishing communication between up to 16 remote links per Wireless RS-485 (Base).

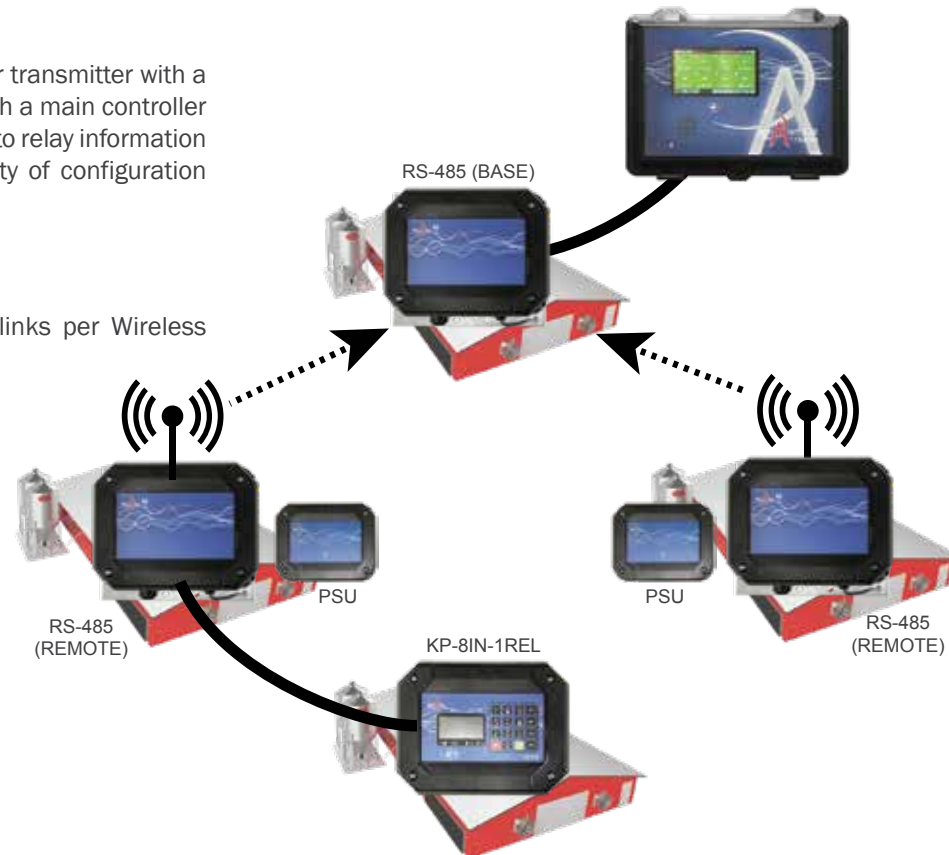



## Agri-Alert™ Specification

	AA 800EZE	AA 128 TOUCH
Number of zones available	8	128
Programmable zone types	temperature dry contact / ELR, burglary	temperature dry contact / ELR, burglary, 4-20 mA, outdoor probe, 0-5 volt
Zone partitioning (grouping)	8	16
Temperature sensor calibration	yes	yes
Number of contacts system can call	8	12
Number of call sequences per alarm	up to 7	no limit
Acknowledge alarm by phone	yes	yes
Alarm restored call-back feature	yes	yes
Call in for temperature / status reports	yes	yes
Programmable recognition time per zone	yes	yes
Programmable start call delay	yes	yes
Programmable alarm recall feature	yes	yes
Outside temp compensation feature	yes	yes
Independent users	up to 10	up to 102
Auxiliary 28 volt / 12 volt DC power output	no/ yes	yes/ yes
Siren output	yes	yes
Output relays (programmable)	yes	yes
Individual zone labeling (on screen)	no	yes
Individual zone voice identification	yes	yes
Individual zone status identification	yes	yes
Remote modules	no	yes
Wireless compatible	no	yes
Rechargeable battery	yes	yes
Display	1" x 2" LCD screen	7" color touch screen
Event buffer (non-volatile)	yes	yes
Alarm memory log	yes	yes
Temperature SP can be set to a curve	no	yes
Telephone line monitoring	yes	yes
Phone line seizure	yes	yes
Bypass zones remotely	yes	yes
Program & Back-up w/PC	yes	yes
System self diagnostics feature (system trouble)	battery, AC supply, siren, fuses & probes	battery, AC supply, siren, fuses, probes & dialer, SBI
Multi language	no	yes
Automatic software update when connected to the internet	no	yes
Ethernet connection	no	yes

Specifications subject to change without notice.



### Peace Of Mind

Agri-Alert is a complete alarm system for monitoring temperature, power, feed and watering system, burglary, bio security and more. The Agri-Alert alarm system constantly monitors your operation and quickly notifies you upon detection of common site problems or failures.

# FLOOR SYSTEMS

**Built for Durability and Strength  
Create Warm, Dry and Comfortable Environment**

Cumberland is the pioneer in plastic poultry slats. Cumberland Poultry Flooring is made from high-impact, virgin polypropylene plastic designed to replace wood or wire slats in poultry housing.

## Performance

- Our slatted floor reduces foot pad related diseases and breast blisters, which are caused by wooden slats. Plastic Slats has a longer lifespan.

## Rot-Proof/Non-Porous

- Our solid plastic construction is rot/corrosion proof, resists microorganisms build-up and sheds waste efficiently

## High Quality

- Made from high impact polypropylene plastic material for durability and easy cleaning
- Corrosion free and does not hide contaminants or harbour bacterial growth
- Available with (or without) UV protection

## Original Cumberland Slats Contain:



Cumberland Logo



Manufacturing Date

## Interlock Design

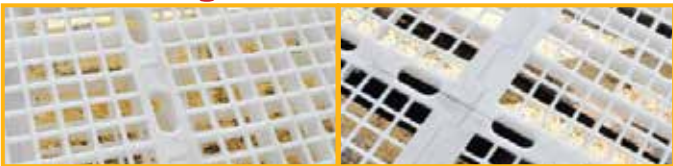

## Models



Comfort Model

Eco Model

## Interlock Design

- Designed with interlock system for all four sides of the slat
- Provides secure attachment to the steel support beam

## No Sharp Edges

- 100% consistence dimensions
- No sharp edges or corners

## Strength

- Strong enough to support the weight of 120kg (265lbs)
- 100% virgin plastic construction without break

## Specifications

Technical Data	Comfort Model (Oval Holes)	Eco Model (Square Holes)
Material	Polypropylene	Polypropylene
Dimension	1020mm x 515mm	1020mm x 515mm
Hole Dimensions	20mm x 45mm	20mm x 20mm
Actual Weight	2.74kg/ 6.04lbs	2.10kg/ 4.63lbs
Colour	White	White



# HEATING SYSTEMS

## Super Saver Heater

The Super-Saver XL heating line is a direct fired heaters that offers **Universal Mount** model which includes variations for both inside suspension hanging and outside mounting.

The inside mount model is a gas circulating heater that is dependable and rugged construction, ideal for closed houses and suitable for all ages and classes of poultry.



The inside mount model is a gas circulating heater ideal for a confinement environment.



The outside mount model is a forced air heater complete with all relevant installation hardware.

**Outside mount** is applicable with the outside mounting kit. The outside mount models are forced air heaters that come complete with all relevant brackets and accessories for installation. Its superior combustion is provided by clean, fresh outdoor air and ensures healthy and safe heating for your poultry needs. All models are available with options for **natural gas or liquid propane**.

### Super-Saver XL Specifications

Model#	Maximum Input	Ventilation	Voltage	Amps
HH-SS-225-XL	225,000 BTUH (65.9kWh)	1000 CFM (1699 m <sup>3</sup> /hr)	240 Volts	4.8 Amps



- Direct spark models available in 225,000 BTU
- High temp aluminized steel burn chamber
- Side swing door for easy access and maintenance
- Diagnostic lights for troubleshooting ease
- Standard adjustable “Y” heat deflector
- 1/3 HP totally enclosed thermally protected motor with sealed bearings
- Standard “1/2” gas cock installed as gas valve
- Back-up safety sail switch
- High limit safety switch (manual reset)
- On/off toggle switch
- Service-Saver enclosed control box
- 30% gas saving vs conventional brooder



The “Service - Saver” enclosed electronic control unit is sealed from debris such as dust and moisture and is accessible through a side swinging door making the unit easily field serviceable.



A side swinging door design gives **easy access** to internal components like the “Super-Saver” control unit and blower motor, making it one of the easiest to service heaters on the market.



The **Electronic DSI Ignition** is standard on all Super-Saver heater models. The heating chamber is made of high temp aluminized steel for superior rust protection. The cast iron burner is enamel dipped to eliminate dust adhesion and rust. The surrounding air intake increases combustion and heat change efficiency.

Super-Saver XL Minimum Clearances	
Ceiling	12” (305mm)
Wall	12” (305mm)
Floor	20” (508mm)



## PuraFire Heater

With one of the lowest carbon monoxide outputs in the industry (CO emissions of 5 parts per million), Cumberland PuraFire Heaters are able to produce 225,000 BTUH Per hour. Each heater is LP or nature gas compatible and can be mounted inside or outside any house. These heaters are constructed of tough, rust-resistant galvanized steel for longevity and durability.

Bottom-draw intake of PuraFire promotes a better control of the air flow into and throughout the entire unit and provides a more efficient mix of air and gas. Cool air channeled along the inside casing, creates a buffer that makes the exterior casing safe to touch. This air pattern results in a unique bent flame design, which greatly increases the flame’s surface area and heat chamber efficiency.



PuraFire igniters are available with stainless steel casing.



Thermostats, Regulators and Hoses

- Consistent, clean burning source of warmth with near 100% fuel efficiency.
- Thermostat operated.
- Intelligent trouble-shooting safety features.
- In case of flame failure, automatic fan shut down stops drafts & gas control lockout prevents gas from escaping.
- 30% Gas saving vs conventional brooder.

- Bottom-draw for better air flow control.
- “Bent flame” design greatly increases flame surface area and heat chamber efficiency.
- Exterior surface is safe to touch.
- Motor assembly, blower, gas valve, control panel and other components are protected from moisture, dirt and dust for longer lifespan
- Swinging doors on each side allow access to all working parts.
- Even heat distribution.





# EVAPORATIVE COOLING SYSTEMS

## Open Top Cooling System



GSI evaporative utilize the natural cooling effect of evaporation to combat seasonal dips in production caused by heat stress. Cumberland offers the Open Top System Komfort Kooler that has been an industry favorite for many years.

### Key Features:

#### Open Top Design



Made of high quality aluminum, this system will give years of dependable operation under the harshest conditions. The Open Top design allows you to see the water jets and easily check water pressure. It also offers access to the spray bar for cleaning. Pre-punched and heavy duty stainless steel components help simplify installation.

#### Water Troughs



GSI's pre-formed square trough serves as a 3 gallon per lineal foot (37.4 liters per meter) water reservoirs. Constructed with corrosion proof, ultra-violet stabilized PVC components, the trough allows unevaporated water to be recirculated back to the holding tank. A perforated tray snaps to the trough to hold pads firmly in place. Injection molded end caps and couplers speed up installation.

#### Water Jet Pump



- All jet pump kits will be factory assembled for easy field installation
- Our new motor is 1Hp 3Ph - 50/60Hz continuous duty motor

## Closed Top Cooling System



GSI's RCS Gen 2 is a combination of simplified and effective evaporative cooling system. It was developed after years of field study and test, ideal for areas with hot and dry climate. RCS Gen 2 is a reliable climate control solution, requiring minimum installation and crafted for simple supervision and maintenance.

GSI only chooses cellulose pads with top quality, made of special cellulose material that provides a large surface area for high cooling capacity. Chemical impregnation protects the pads from damages influenced by outdoor weather.

### Key Features:

#### Closed Top Design



Easy, convenient and flexible opening during cleaning and servicing



Practical clip - retainers allow a simple and quick replacement of the pads, saving time and labour



Top profile with perforated pipe and deflector for an even distribution on water along the pads



Easy installation and pipe cleaning.



Design of Float Valve is to assure the compact design of integrated trough and tank



Bigger Spray Pipe design, better spray effect



Simplified system with huge water capacity allows easy installation and maximum cooling effect with minimum hassle. 3.96 gallon per lineal foot (49.2 liters per meter)

# CURTAIN MACHINES

Protect the health of your investment with a properly controlled curtain system. Cumberland's curtain machines deliver powerful performance and reliable operation with durable components to withstand a rigorous environment.

## PowerTrak Linear Drive and Systems

The superior quality and design of the PowerTrak has produced maximum performance and efficiency. This model is a second generation of super strength power pulley systems introduced by Cumberland. It has been completely upgraded with service in mind and boasts many performance and durability enhancing features while maintaining the strong points of its popular predecessors, Power Curtain and Power Vent.

## PowerTrak Optional Chain and Sprocket

Depend on the superior quality and design of Cumberland power systems for maximum performance and efficiency. A proven standard in vent applications was set with the introduction of the optional Chain and Sprocket PowerTrak which minimizes alignment problems and cable breakage in vent applications.

- Upper and lower auxiliary contacts for enhanced Evolution features
- 15% increase in load block support surface for greater life
- Convenient hinged springlock door that is easily removed
- Channel lock "trak-drive" system captures load block
- Built in head bracket with needle bearing pulleys
- Easy adjust springcam limit switch system
- Modular construction for ease of service
- Greater protection from the elements
- 5,000 pound capacity



### Pulley Assembly

Solid construction and rust resistant materials make the sprocket controller a reliable workhorse year after year.



### Load Block

Light but hard aluminium load block.



### Spider Coupling Lovejoy Coupling

The PowerTrak utilizes a threaded block and drive screw directly coupled to a direct drive gear motor.



### Inner View

### High Limit Adjustment Collar

Adjustable Collar to control the travelled distance.



### Lower Limit Adjustment Collar

Adjustable Collar to control the travelled distance.



### ApringCam Limit Switch Actuator

Isolated primary and secondary limit switches allow for back-up protection.

### Actual View

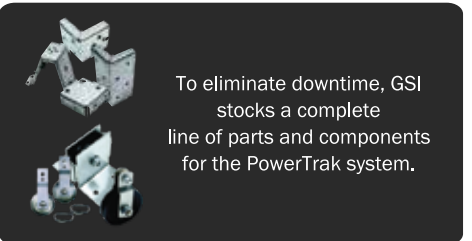

To eliminate downtime, GSI stocks a complete line of parts and components for the PowerTrak system.

## Emergency Curtain Drop Curt-O-Matic II & III



- Simple 3-wire hookup.
- Available in 240 volt models.
- 5 years product defect warranty.
- Curtain chain kit.
- Optional: drop delay from 1 to 10 minutes

- Optional: Curt-O-Matic III can be hooked up to your alarm system's electronic audible, to signal alarm if arm on system should drop.
- Easy installation.

## Gear Up to Powerful Performance

Protect the health of your investment with a properly controlled curtain system. AP's curtain machines deliver powerful performance and reliable operation with durable components to withstand a rigorous environment.

### Curtain Controller

AP's Curtain Controller is a screw driven automated curtain machine with a heavy duty 15, 30 or 60 RPM motor. Multi-directional, frame mounted, header pulleys are standard.



Polyethylene pulley covers provide additional weather protection.



A plastic water resistant junction box is accessible from the outside of the curtain controller.



Solid construction and rust resistant materials make the sprocket controller a reliable workhorse year after year.



The Curtain Controller utilizes a threaded block and drive screw directly coupled to a direct drive gear motor.



Isolated primary and secondary limit switches allow for backup protection.



The drive block assembly features a removable nylon insert in a heavy-duty cast iron drive block simplifying cable/chain installation and ease of maintenance. This design also decreases friction and provides wear characteristics superior to conventional brass drive blocks. UHMW polyethylene guide wheels ensure smooth travel, proper alignment and stability.

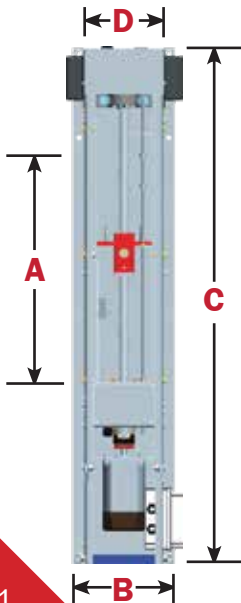

### Curtain Machine Specifications

Actuator	H.P	Voltage	Frequency	Amp Draw	Travel Speed	RPM
15 RPM Curtain Controller	1/12	115V	60Hz	1.0 Amps	3" per minute	15
30 RPM Curtain Controller	1/8	115/220V	50/60Hz	1.7 Amps	6" per minute	30
60 RPM Curtain Controller	1/6	115V	60Hz	1.8 Amps	12" per minute	60
A.T. Newell	1/2	115V	60Hz	6.0 Amps	3" per minute	1725
Auto-Air Actuator	1/8	115V	60Hz	1.8 Amps	15" per minute	1625

### Curtain Controller Dimensions

Length	"A" Travel	"B" Width	"C" Length	"D" Width Less Flange	Weight
24" (61cm)	22" (55.9cm)	10.2" (25.9cm)	52" (132.1cm)	9.5" (24.1cm)	110lbs. (49.9kg)
36" (91.4cm)	34" (86.4cm)	10.2" (25.9cm)	64" (162.6cm)	9.5" (24.1cm)	130lbs. (58.9kg)
48" (121.9cm)	46" (116.8cm)	10.2" (25.9cm)	76" (193cm)	9.5" (24.1cm)	150lbs. (68.0kg)
60" (152.4cm)	58" (147.3cm)	10.2" (25.9cm)	88" (223.5cm)	9.5" (24.1cm)	160lbs. (72.6kg)

Specifications are subject to change without notice.





# PREFABRICATED STEEL HOUSING

**Our energy efficient buildings can double net payback to growers when compared to other conventional buildings.**

The 100% steel construction structures are definitely state-of-the-art of live production buildings. No plastic ceilings or wood walls. The structure's negative pressure ventilation is unmatched with its durable operating design features. Winter weather heat loss is minimized, optional, bi-flow selectable heat exchanger baffle system. When compared to other buildings on the market, our structures' attention to detail in building design, use of premium materials, day-to-day operating efficiency and its anticipated 35 year useful life, no greater value can be found anywhere. We are confident that once you have had opportunity to learn more about our buildings, you'll agree that structures is the industry's choice in building design and production.

## Features & Benefits:

- Excellent FCR and uniform growth
- Fully airtight construction
- Fiberglass wool insulation with R12 to R29 insulation value to save energy cost
- GSI Quality assurance - each construction material is inspected & tested thoroughly for accuracy
- Professionally engineered single storey, double storey & elevated slat flooring's buildings
- Code Acceptance: Steel framing is backed by national building codes
- Single span structure from 40ft (12m) up to 80ft (24m) width & wider
- Made of High Tensile Structural Steel with heavy Zinc Coating for structure's rigidity & longevity
- Flexible: Steel can be designed for longer spans that create more open floor plans & fewer load-bearing walls
- Safety: The strength of steel offers greater protection to you & your family during inclement weather.
- Pest-Proof & Fire Proof
- Natural Attic ventilation design for heat & moisture exhaust
- Use 25% less energy in ventilation fans vs conventional house
- Use 30% less energy in heating/ brooding
- Gatorshield galvanized tubing frame
- Efficient climate control engineering
- 50-70% reduction on Insurance claims
- Uncompromising design standards
- Endwall & Sidewall are "C" channel framing kits
- Engineered Structural Tubing Truss
- Pre-Engineered 100% Galvanized steel construction
- Pre-Engineered for components installation
- Roll-Seal doors (Manual or automated control options)
- Thicker 4" walls (Industry standard walls are only 3 1/2")





**AGCO GSI (Malaysia) Sdn.Bhd.** (392746-V)

Plot 218, Jalan Perindustrian Bukit Minyak 6, Kawasan Perindustrian  
Bukit Minyak, 14100 Simpang Ampat, Penang, Malaysia.

Hotline : +604 505 7598

Fax : +604 505 9879

Email : [enquiry.my@agcocorp.com](mailto:enquiry.my@agcocorp.com)

Website : [www.gsiasia.net](http://www.gsiasia.net)



Cumberland is a part of GSI, a worldwide brand of AGCO.

Printed in Malaysia © 2019 All right reserved.

Cumberland reserve the right to change  
designs and specifications without notice.