

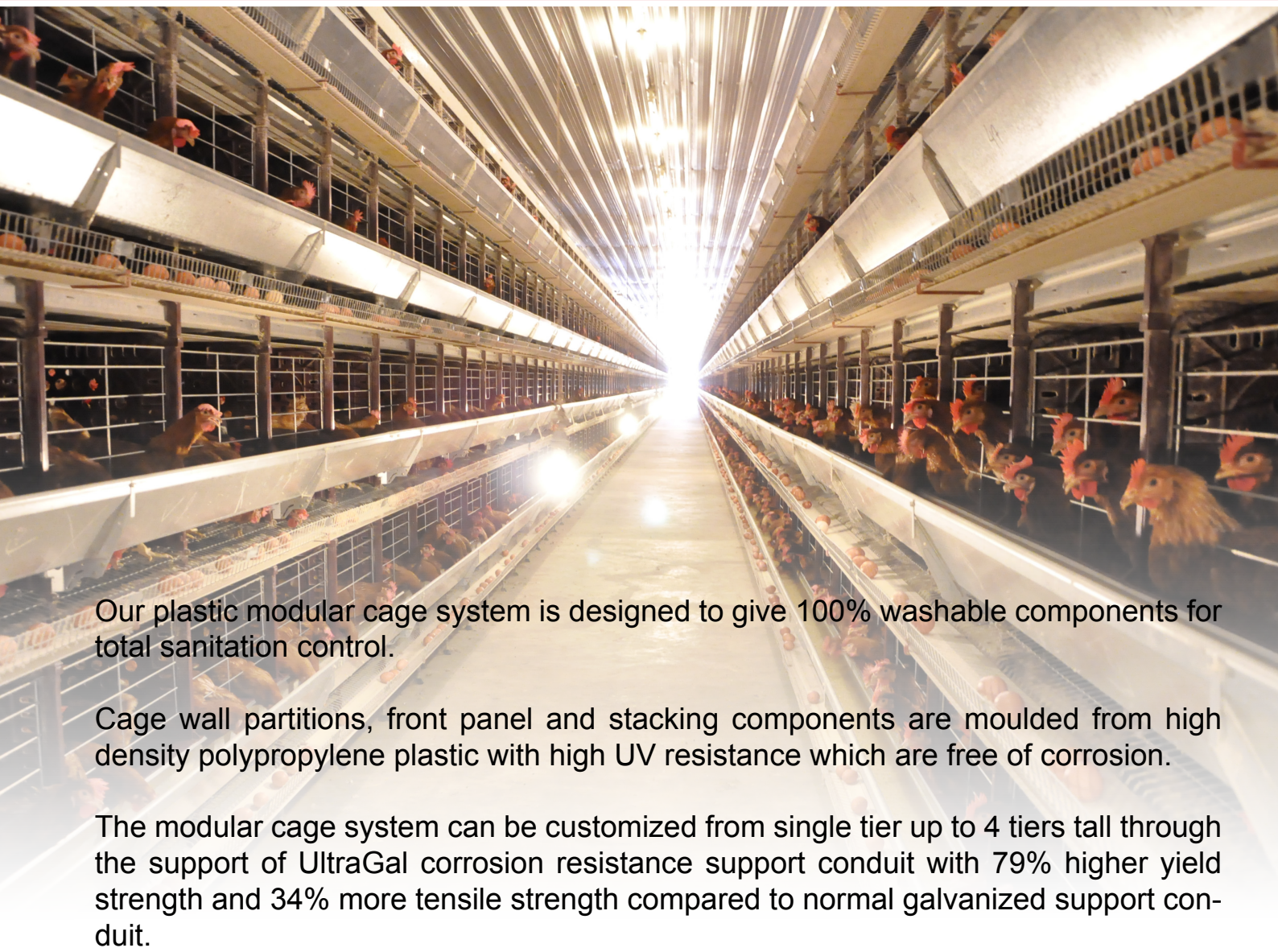

Modular Cage System



Our plastic modular cage system is designed to give 100% washable components for total sanitation control.

Cage wall partitions, front panel and stacking components are moulded from high density polypropylene plastic with high UV resistance which are free of corrosion.

The modular cage system can be customized from single tier up to 4 tiers tall through the support of UltraGal corrosion resistance support conduit with 79% higher yield strength and 34% more tensile strength compared to normal galvanized support conduit.



Egg collection system

Variable speeds control of egg collection and egg belt drive system can be adjusted to move the egg belts up to 300 cm per minute.

A simplified timed egg loading system is designed to ensure eggs with perfect transfer. The open design system is to allow manure and dirt to be separated from eggs resulting cleaner and hygienic eggs.

Overhead or in-floor cross conveyor is available with the system for transporting eggs onto a appropriate location or tenderized eggs room for collection.



Travel hopper feed dispenser



Heavy duty manure removal system

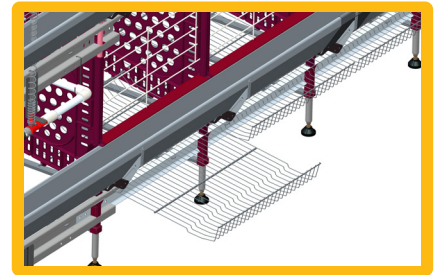

Individual removable floor mesh, ease for maintenance and replacement

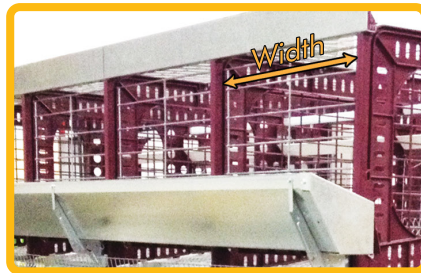

Standard Width : 2.0 feet
Optional Width : 2.5 feet



Single piece roll up door

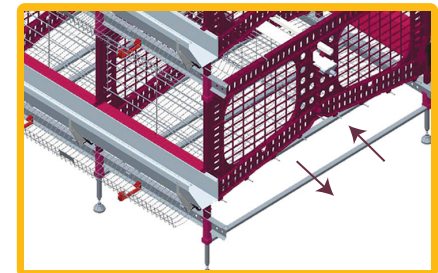

Plastic wall partition with perforated holes for better air flow ventilation



Specifications

	Height	Inside Leg (center-to-center)	Overall Width
3 Tier	2502mm	1242mm	1920mm
4 Tier	3159mm	1242mm	1920mm

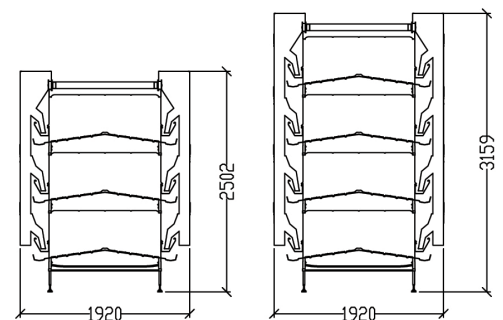
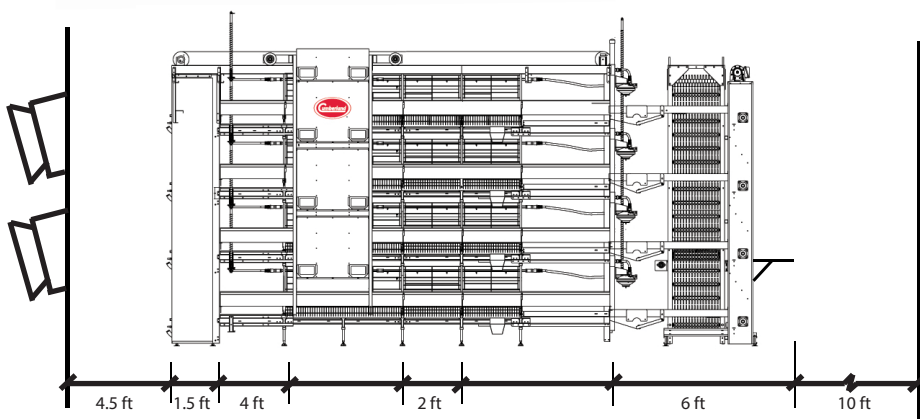

Plot 218, Jalan Perindustrian Bukit Minyak 6,
Kawasan Perindustrian Bukit Minyak,
14100 Simpang Ampat, Penang, Malaysia.
Tel: 604 505 7598 Fax: 604 505 9879



Cumberland is a part of GSI, a worldwide Brand of AGCO
copyright © 2017 by AGCO GSI Malaysia | Due to continual improvements,
Cumberland reserves the right to change designs and specifications without notice.

For more information on Cumberland's many products and services, contact your local representative or visit us online at:

www.gsiasia.net